

■ Connecting the measuring unit

This measuring unit uses an interface that is compliant with the USB (Universal Serial Bus) 2.0 FS (Full speed) standard, and can be connected directly to a personal computer or hub.

Note

Use a personal computer that is compatible with the recommended system requirement (refer to "Specifications").

■ Installing software

The software available on the Magnescale website can be used by installing in a personal computer. Refer to the software instruction manuals available on the Magnescale website for the software installation and operation methods.

Magnescale website

<http://www.magnescale.com/mgs/language/english/product>

Digital Gauge > DS805S/DS812S

■ Mounting Instructions

Installation environment

- Do not use the unit in places where it may receive excessive shocks. Otherwise the inside of the unit may be damaged or the unit may become unable to produce normal output signals.
- Locate the measuring unit at least 10 cm away from a strong magnetic source. (The measuring unit must not be used in magnetic fields exceeding 5 mT.)
- Do not place the measuring unit where it is exposed to splash of water or oil.

Mounting

- When attaching and removing the feeler, use the supplied spanner. Be careful not to apply torque exceeding 0.1 N·m to the spindle. This could lead to a breakdown. To prevent the feeler from becoming loose, it is recommended to either attach the supplied spring washer (nominal size: 2.5) or use a screw lock. (tightening torque reference value: 0.05–0.06 N·m)

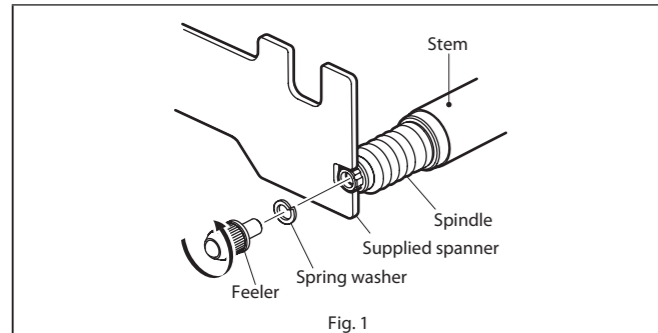

- Fix the cable in a suitable position to prevent possible cable breakage. Never handle the cable by forcibly pulling or bending it. (Inside bend radius 50 mm or more)
- The measuring accuracy depends on the mounting parallelism. Adjust the squareness to the measuring surface or the parallelism to the movement to within 0.02 mm/14 mm.
- After the stem is secured, do not apply force in the rotational direction. This could cause a failure.

DS805SR5 / DS805SLR5 / DS812SR5 / DS812SLR5 / DS812SVR5

- The measuring unit comprises ball bearings. Therefore, chucking the stem of the measuring unit too tightly when mounting may damage the spindle and prevent its smooth motion.
- Attach the stem by tightening a screw into the slot as shown in Fig. 3. Never attach by screw threading in the $\phi 8$ mm hole vertical direction, pressing the stem, and then tightening with a screw. This could result in poor sliding and low precision.
- Be absolutely sure to chuck the stem part when mounting the measuring unit.

- Using Fig. 2 as a reference, select which holder to have ready at the mounting side.

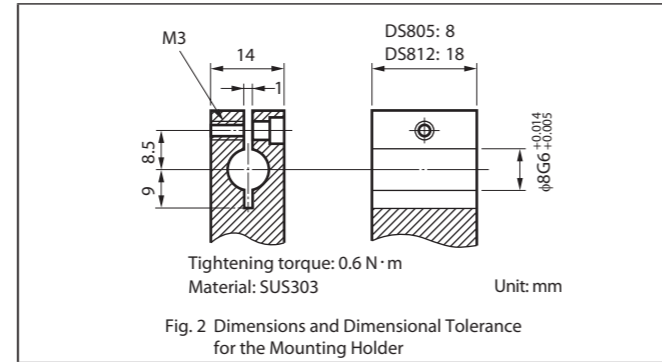

DS805SFR5 / DS805SFLR5 / DS812SFR5 / DS812SFLR5

- Be sure to use the supplied tightening nut, wave washer, clamp spanner and pin to mount the measuring unit. (Fig. 3)

Note

The tightening torque should be roughly that needed to completely flatten the wave washer.

Recommended tightening torque: 0.6 to 1.0 N·m
Maximum tightening torque : 2.0 N·m

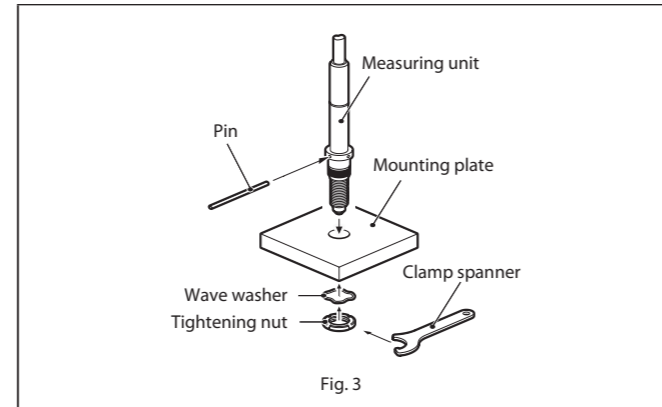

- Using Fig. 4 as a reference, select which holder to have ready at the mounting side.

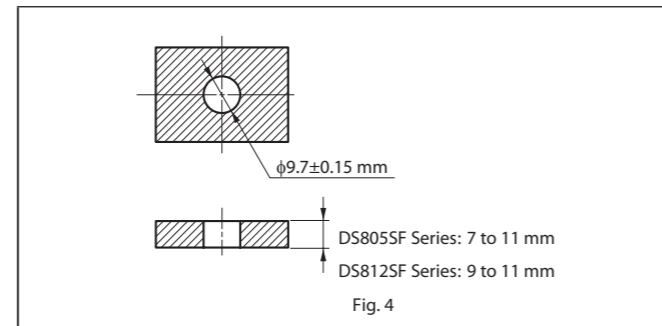

■ Maintenance

- Calibration is recommended every year.
- This unit is equipped with an anti-dust bellows on the spindle. Organic solvents, ozone, ultraviolet rays, and other adverse conditions in the ambient atmosphere can cause rapid deterioration of the anti-dust bellows. When using in these environments, replace anti-dust bellows periodically (every six months to one year).

■ When providing an IP67 protection grade (DS805SLR5 / DS805SFLR5 / DS812SLR5 / DS812SFLR5)

Note

To prevent damage of the measuring unit:

- Fix the measuring unit after attaching the hose elbow.
- Hold the L-shaped bracket part of the measuring unit when performing the following procedure. Make sure not to apply force to other parts.

Procedure

- Remove the cap.

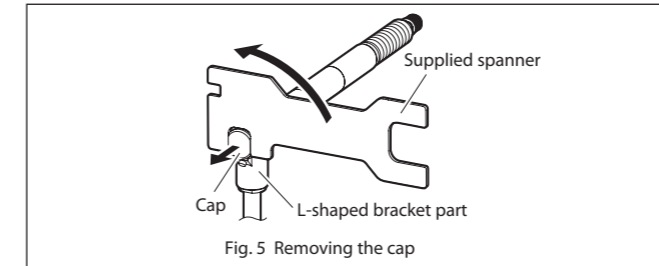

- Mount the hose elbow and set the position. (Refer to Fig. 6.) Tighten the M5 screw with the supplied spanner by holding the hose elbow and the L-shaped bracket part of the measuring unit.

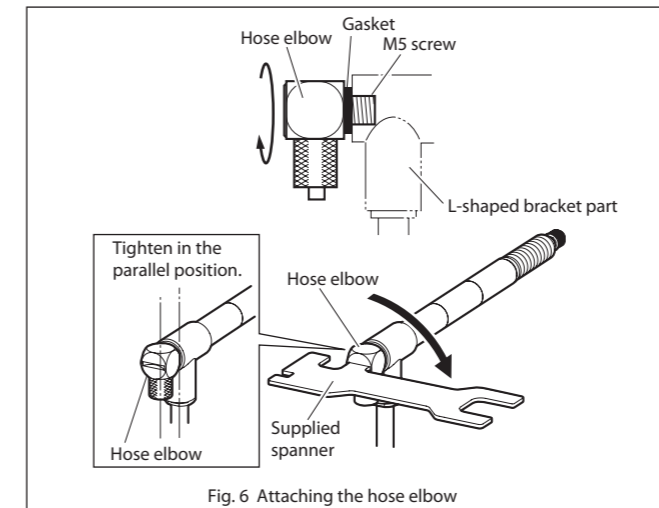

■ Troubleshooting

The operating status of the measuring unit can be checked using the LED indicator.

LED lighting color	Details	Remedial action
Lights in blue.	The power is turned on. Normal operation is now performed. The reference point has been detected.	-
Blinks in blue.	The power is turned on. The reference point standby status is established or the reference point is being detected.	When the reference point is used, turn on the power with the spindle extended as far as possible (Note: in case of SV type, with the spindle contracted), and then move the spindle 1.5 mm or more. When the power is turned on with the spindle stopped near the reference point position, it may not be possible to detect the reference point or the reference point may shift.
Blinks in red.	The signal level of the measuring unit is abnormal.	After dealing with the factor suspected to be responsible for the alarm, reset the software or turn the power back on.
Lights in red.	The maximum response speed has been exceeded. The signal level of the measuring unit is abnormal. Serial communication trouble has occurred. Normal operation cannot be performed due to the effects such as external noise etc.	If the same symptoms persist even when the power has been turned back on, the measuring unit might be malfunctioned.
Off	Power OFF	If the same symptoms persist even when the power has been turned on, the measuring unit might be malfunctioned or the cable might be broken.

- Attach the $\phi 4$ mm air tube.

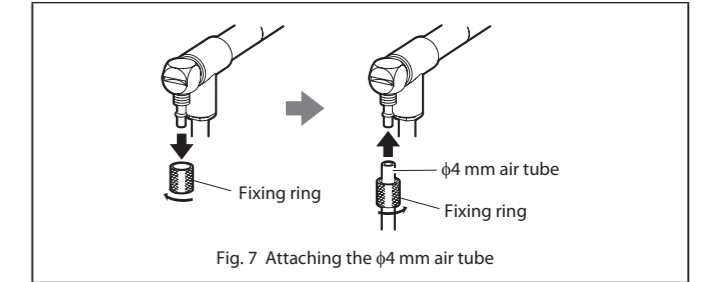

Place the end of the air tube in a location where it will not come into contact with water, oil or dust.

■ When driving the unit using air (DS805SLR5 / DS805SFLR5 / DS812SLR5 / DS812SFLR5 / DS812SVR5)

After attaching the air tube, construct the air pressure circuit as shown in Fig. 8.

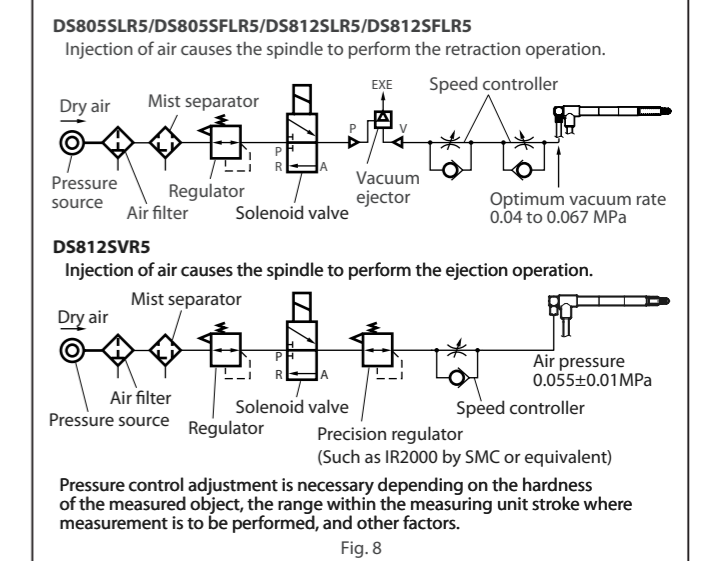

If the spindle ejection speed is too fast, an error may appear on the display the moment that the workpiece is touched. Excessive impact may dislodge the retainer inside the bearing, causing the measuring range to be reduced. In this case, use a speed controller as shown in Fig. 8 to adjust the spindle speed.

